

# REXON DEA-DUO

## BASIC CHARACTERISTIC



**REXON-DEA-DUO** turnstile is the best choice for the environment where the space is limited and high access frequency and security is required. This turnstile has double capacity that is provided by couple of rotors that ensure the individual passage in each direction. Robust full-height construction, high quality, trouble-free individual operation and simple mechanism are the hallmarks of the **REXON-DEA-DUO** turnstile making it ideal for high security applications where the full automatic identification of people is required. Anti-corrosive surface of all components and high quality final finish of **REXON-DEA-DUO** turnstile guarantee long durability and reliable operation not only in indoor environments but also under harsh and extreme conditions of outdoor installations. Modern design, construction and colour variability make **REXON-DEA-DUO** turnstile to be a unique part of access control system.

Turnstile REXON-DEA-DUO is offered with the following types of drive unit:

### Motor drive unit MT (standard):

**REXON-DEA-DUO** turnstile motorised version provides high comfort along with reliable and maintenance-free running:

- effective blocking system in combination with motor-driven unit
- automatically adapts the rotation speed to the users
- provides a high level of safety - in the event the turnstile detects an obstruction it will stop moving
- silent and fluent running
- possibility to set smooth final phase of rotation

Motor-driven unit is supplied in two variants:

- 1) **FAIL-LOCK:** turnstile is blocked during the power failure
- 2) **FAIL-SAFE:** turnstile is unblocked for free passage during the power failure

### Mechanical unit:

- enables setting - one of directions permanently blocked and the other unblocked for free passage
- blocking system prevents the turnstile reverse during passing

This type of turnstile is applied to regulate and control the number of passing people in one-direction and it is not controlled by any superior devices. Mechanical unit does not require the power supply.

### TURNSTILE MATERIALS AND SURFACE TREATMENT:

**Frame:** steel sheet, thickness 3mm, surface-finished by powder coating (standard: RAL 9005 GS-black)

**Covers and roof:** steel sheet, thickness 1.5mm, surface-finished by powder coating (standard:RAL 5010 GS-blue)

**Top and roof sides:** steel sheet, thickness 1.5 mm, surface-finished by powder coating (standard:RAL 9005 GS-black)

**Push bar:** stainless tube  $\varnothing$  108 mm (standard: polished)

**Wings of barrier:** stainless tube  $\varnothing$  40 mm (standard: polished)

**Internal barrier:** steel tube  $\varnothing$  22 mm (standard: RAL 9005 GS-black)

Other mechanical parts of turnstile are finished by galvanic zincing or blackening.

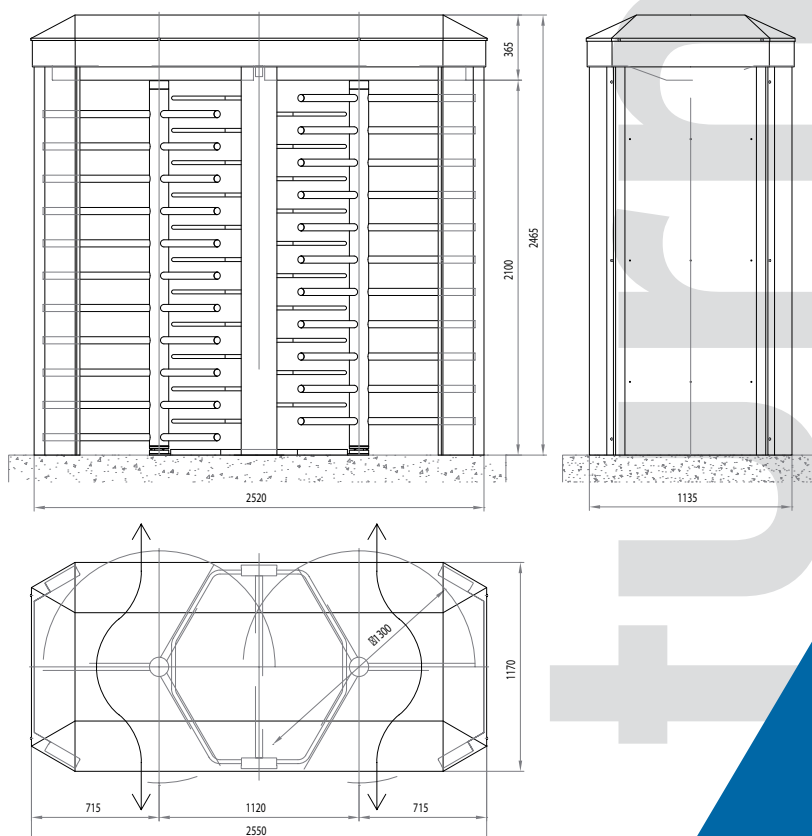

## Interface:

Turnstiles are controlled by microprocessor control units that is equipped with high effective processor. Control electronics is equipped with extensive subsystem that enables the connection of many input and output devices, all of them are galvanically isolated.

- device operating by status signals, serial bus RS 485, USB or Ethernet (with external converter)
- configurable two-state outputs about turnstile status
- motor control by digital power bridges with overload protection and current measurement
- include generating log file with a list of all faults accompanied with time/date mark
- possibility of remote firmware upgrade
- wide range of configuration and diagnostics parameters for remote customization using T-CONF software
- full remote control of turnstile network including passage counters status shown on PC using T-MON program
- possibility to connect the supplementary ultrasonic, laser or infra-red sensors
- enables back up accumulator connection directly in the turnstile (supports charging, measuring and auto-switching for power supply from accumulator in case of power failure)
- connectors for all input/output signals for fast and easy installation, service and replacement
- top-quality control electronics enables high operational reliability

## Operating modes:

If input signal from access control system or button controller is received it is possible to turn round the turnstile 120° and by that way enable the passing to one person.

For each way of direction it is possible to define the different operating modes:

1. free passage
2. controlled passage
3. permanently blocked

This setting can be set-up for any direction eventually for both directions at the same time.

## BASIC TECHNICAL PARAMETERS

### Table of drive unit electric parameters:

Type of drive unit	Rated supply voltage	Power consumption in basic operation modes		
		Standby mode break activated / break released		Transit mode
Motorised FAIL-LOCK	12VDC	6 W	25 W	50 W
Motorised FAIL-SAFE	12VDC	25 W	6 W	30 W

- standard range of working temperatures: +10°...+50°C
- range of working temperatures (with heating module) -25°... +50°C
- range of storage temperatures 0°... +50°C
- maximum relative humidity 80% (non-aggressive environment)
- MCBF: 3 000 000 cycles (number of cycles before error)

The number of passages, in dependence on type of control electronics, operating mode and the way of identification of passing people, rates between 30 to 60 persons per minute.

Increase of power supply on motor drive unit with automatic heating module is 48 W. The power supply can be also increased by using optional accessories.



## ACCESSORIES

### Additional locking:

Additional electromagnetic brake to increase the turnstile resistivity against illegal passage.

### Columns and holders for accessories:

Columns and holders for placing of identification readers or other accessories (for example: LED information panel).

### Lighting:

Lighting of turnstile interior.

### Anchoring frame:

Steeley frame to fix the turnstile for example through the stone block paving.

### Traffic-Light information panel:

- information about the turnstile accessibility in set direction
- information about transit permission based on evaluation by access control system
- information about invalid card

### Touch control panel:

- animation of identification card alarming necessary identification of the passing person
- information about the turnstile accessibility in set direction
- information about transit permission based on evaluation by access control system
- information about reading of invalid identification card

### Back-up accumulator:

During a power failure the accumulator ensures the turnstile continuous operation for a period of minimally 6 hours. It is possible to use two backup modes.

- accumulator in external power supply unit (back up > 6 hours)
- accumulator inside the turnstile (emergency back up about 30 minutes in case of feed cables disconnection).

### Counter:

- included in program T-MON
- it is possible to connect the external counter

### Identification systems:

In order to identify the passing people, it is possible to connect to these turnstiles REXON-DEA-DUO any type of barcode, magnetic card, proximity chip card, smart card, biometrical sensor.

### Software accessories:

**COMMUNICATION CLIENT** - software that enables the connection of turnstile network with PC. This program runs on the background (its activity is hidden) and enables to any PC with valid authority to make setting and control the turnstile network.

**T-MON** - program that enables to control the turnstile system from any PC with valid authorization in customer's network. Remote control of the same turnstile is possible from different PC at the same time. It is fully graphic application that can be used even with touchscreen monitors.

**T-CONF** - program that enables to change the turnstile configuration, configuration backup, record new configuration, error report and vyupustit z textu firmware upgrade. It is localized to many world languages. It is possible remotely connect to any turnstile through Internet after fulfilment of all network qualifications.

### Specific variants:

- stainless steel design
- custom colour in spray according to RAL
- economy variant of the push bar from steel tubes, surface finished by zinc dipping