

EASYGATE SPT



EasyGate SPT: A complete entry control solution designed to accommodate the rigors of public transport environments. Capable of accommodating the unique challenges found in the most demanding of market segments with a high aesthetic ergonomic design and proven high-level security performance. Advanced infrared optical sensor arrays coupled to a state of the art software detection algorithm and a unique drive system provide a superior level of reliability that effectively lowers the cost of ownership. Safety and security are uncompromised; deliberate fraudulent entry attempts such as tailgating, climb-over or under are easily detected triggering the gates local as well as remote alarm outputs to alert staff while safely deterring the unauthorized entry.

Our unique new patented magnetic direct drive system is manufactured in-house utilizing far fewer moving parts than conventional drives systems.

EasyGate SPT was specifically designed to withstand considerable abuse found in high throughput public environments that typically wreak havoc on conventional motor/gearbox drive systems. The pleasing open cabinet design not only looks good but is solid & fully tested as well as „real world“ qualified for operation in harsh temperature and humidity environments. We also offer a choice of square or rounded fronts and various finish options that can suit any corporate lobby application that may require a robust reliable solution only found in this market segment.

BENEFITS

- PATENTED - DIRECT DRIVE UNIT
- DESIGNED SPECIFICALLY FOR PUBLIC TRANSPORT
- INTEGRATION OF TICKET VALIDATOR/READER
- HIGHLY RESISTANCE TO DUST AND HUMIDITY
- COMPACT CABINET WIDTH DESIGN: 180MM
- PASSAGE SCHEDULER- AUTOMATIC TIME PROGRAMMING
- DESIGNED FOR EASE OF CUSTOMIZATION
- RUGGED INDUSTRIALIZED CHASSIS

Materials and surface finish treatment:

Cabinet:	brushed stainless steel AISI 304
Top Lid:	brushed stainless steel with black coloured glass endings
Barrier Type:	10 mm acrylic barrier panel
Side infill panel:	6 mm toughened glass panels

Dimensions:

Cabinet height:	999 mm
Cabinet length:	1.500 mm
Cabinet width:	180 mm (same cabinet width for side and middle cabinet)
Standard passage width:	550 mm
Standard Disabled access width:	920 mm

Standard equipment:

Advanced Magnetic Direct Drive System	Audible local & remote alarm for unauthorized passage
Sophisticated Control Logic for safe and secure passage	Compact 180 mm width of cabinet
36 pairs of Infrared Optical Detection Sensors	Brushed or Satin Stainless Steel Finish - ANSI 304
Accommodation for Validation or Reading systems	Tempered glass barrier or acrylic wing panels



Options & accessories:

- Choice of cabinet designs (round, square, or custom)
- Optional surface finishes (Stainless / Brass / Black / RAL-Color / Custom)
- Optional top finishes (Stainless / Glass / Marble / Corian / Custom)
- Barrier panel options: (Clear / Frosted / Polycarbonate / Logo Etched)
- Intuitive accent lighting above Proximity Reader to guide the user
- Instructional status light (Green Arrow / Red cross)
- Barrier Panel LED edge lighting: Glass or Acrylic
- Mounting Bases: facilitate surface mounting without fastening to floor
- Remote Control Consoles & Touch Screen Displays

Operating environment:

- Configurations: Indoor / Outdoor with roof / Outdoor without roof
- High resistance to the effects of dust and humidity
- Operating temperature: 0°C to +50°C (-20°C with optional heating module)

Communication interface:

Input / Output facilities: RS485 / Ethernet / USB / Others

Power supply:

Power supply input (low voltage): 13.8V DC

Detection and safety sensors:

Our 36 pairs of Advanced Infrared Optical Sensors manage:

- Single passage detection
- Distinction: permitting passage of roller bag
- Safety zone sensing to prevent injury
- Fraud detection: Tailgating / Cross-over / Crawl-under
- Positive passage confirmation via remote output

Emergency: Upon an emergency input signal - Barrier panels automatically open in the Exit direction. Panels will reset automatically when input is cleared.

Remote control:

Our exclusive TMON software application facilitates remote control and on-line monitoring of turnstiles from a standard PC or workstation.

The Passage Scheduler application allows programming of scheduled automatic events and remote single passage control.

Magnetic Direct Drive unit (MDD):

Our „State of the Art“ proprietary drive system design does not utilize a standard mechanical gearbox. The brushless motor drive system is quite unique & provides exceptional reliability and maintenance-free operation with fewer moving parts and inherent resistance to the effects of dust and humidity. The MDD system also provides for adjustable speed & torque control capability - allowing the systems to be pre-programmed for your specific application and/or fine tuned later in the field. Such tuning facilitates customized set-up of desirable configurations including: barrier panels locked in the entry direction while allowing push-through for exit. Our engineers have raised the bar with respects to features, aesthetics & reliability significantly lowered your cost of ownership without compromising.

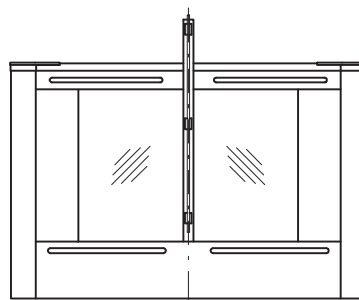
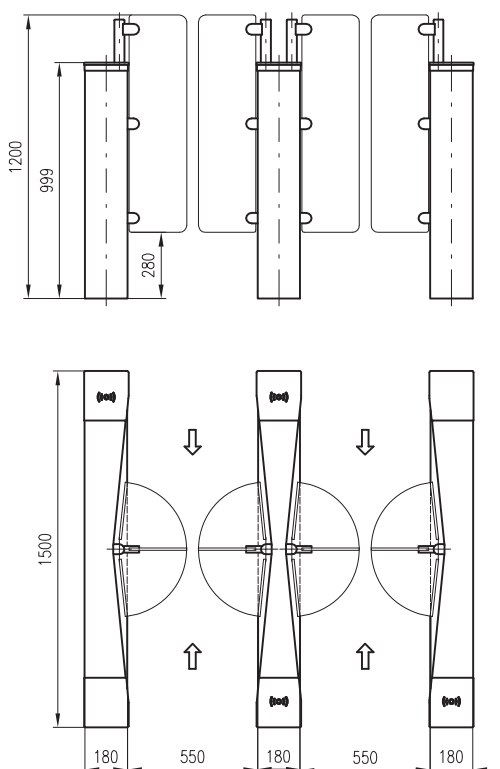

* Specifications are subject to change without prior notice.